

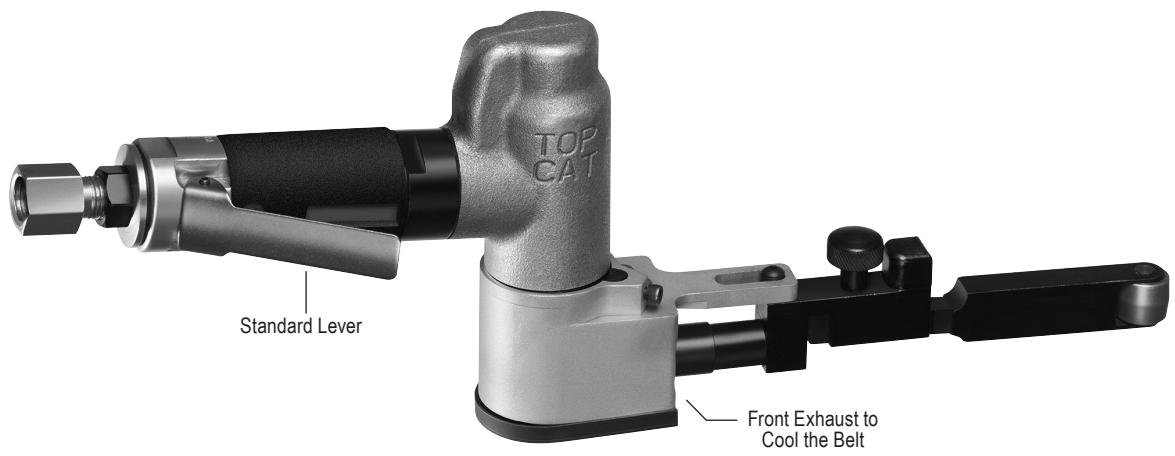

# Belt Sander

## 300BL/K



The 300B Series is offered in a version with 4550 SFPM.

Belt Width	Belt Length	Rated Speed	Lever Style	Model Number
1/2 Inch	18 Inch	25000 RPM (5700 SFPM)	Standard Lever	300BL;25000;S1845
			Safety Lever	300BK;25000;S1845
	20 1/2 Inch		Standard Lever	300BL;25000;S20545
			Safety Lever	300BK;25000;S20545
	24 Inch		Standard Lever	300BL;25000;S2445
			Safety Lever	300BK;25000;S2445
3/4 Inch	18 Inch		Standard Lever	300BL;25000;S1866
			Safety Lever	300BK;25000;S1866
	20 1/2 Inch		Standard Lever	300BL;25000;S20566
			Safety Lever	300BK;25000;S20566

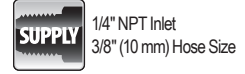
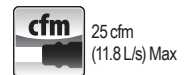
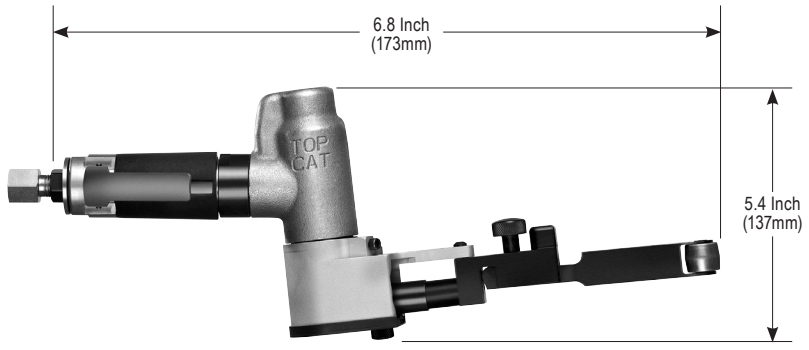

### 300B Alternate Options

#### STANDARD EQUIPMENT

- Tool
- Operating Instructions and Service Manual
- Wrenches (sizes based on options)

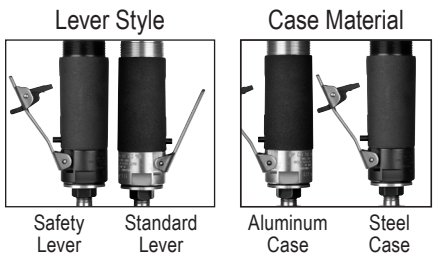

#### Belt Arm Assemblies

Belt Width	Belt Length	Part Number
1/2 Inch	18 Inch	AA-FBCT-S1845
3/4 Inch	18 Inch	AA-FBCT-S1866
1/2 Inch	20 1/2 Inch	AA-FBCT-S20545
3/4 Inch	20 1/2 Inch	AA-FBCT-S20566
1/2 Inch	24 Inch	AA-FBCT-S2445